

Reliability in Action

Wheeled Loader LG958F



Wheeled Loader L958F



L958F

The new F-series wheeled loaders from SDLG offer high performance and reliability, backed up by a world-class support network.

The L958F comes with a modern design and many improvements, for a machine that really delivers. With its 3.2m³ bucket, this loader is engineered for high productivity and will give you an excellent return on your investment. All SDLG wheeled loaders are rigorously tested to ensure reliability in action.

- The design of the L958F ensures that service and maintenance is easily handled, with excellent accessibility throughout the machine.
- The single joystick guarantees precise, easy and comfortable operation of the loader arm and bucket, reducing operator fatigue.

- 1** High breakout force, a rated load of 5 400 kg and a new 3.2m³ bucket design for improved efficiency and productivity. A wide range of available attachments ensures the machine's versatility.
- 2** A powerful and efficient 6 cylinder engine matched to a new SDLG transmission delivers maximum torque from the engine to the wheels.
- 3** Larger cab with 20 % more glazing for improved visibility, safety and efficiency. Superior air conditioning for greater operator comfort.
- 4** Optimised maintenance intervals now offer even better machine availability. The superb SDLG dealer network is there to support all your maintenance and repair needs.

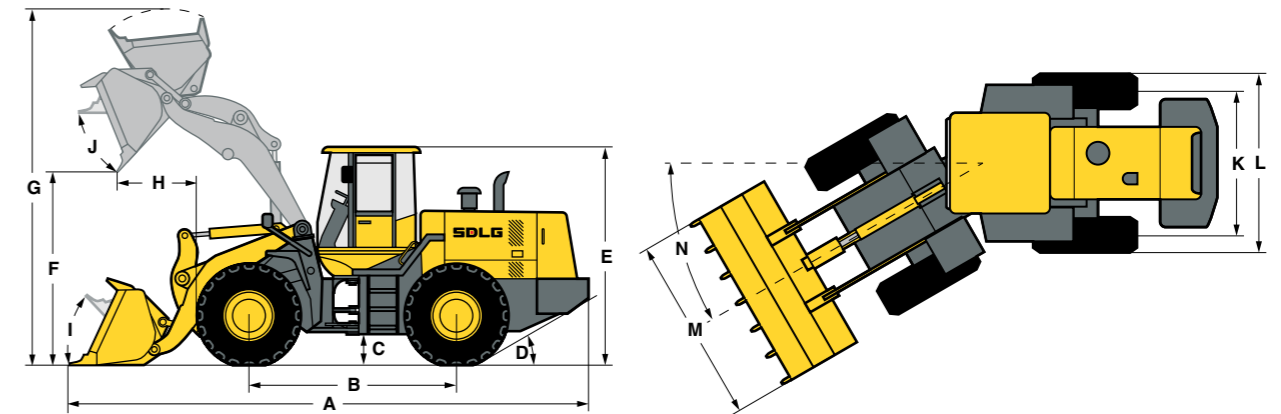

Description	Specification
Operating weight	17 130 kg
Standard bucket capacity	3.2 m ³
Lift capacity (rated load)	5 400 kg
Maximum breakout force	175 kN
Dimensions	
A. Overall length	8 280 mm
B. Wheel base	3 300 mm
C. Ground clearance	420 mm
D. Approach angle back	30°
E. Overall height	3 410 mm
F. Dump height	3 100 mm
G. Overall operating height	5 600 mm
H. Dump reach	1 120 mm
I. Roll back angle ground level	46°
J. Roll back level full height	45°
K. Track width	2 190 mm
L. Machine width	2 785 mm
M. Bucket width	3 024 mm
N. Steering angle	38°
Engine*	
Model	Dalian Deutz BF6M1013
Type	Watercooled, 4 stroke, 6 cylinders in line, direct injection, turbo charged
Rated power (SAE J1349)	165 kW @ 2 000 rpm
Maximum torque	925 Nm
Cylinder bore stroke	126 / 130 mm

* Engine type may vary according to market

Description	Specification
Transmission	
Type	SDLG VRT200, fixed shaft electric-hydraulic shift
Number of gears	4 forward, 4 reverse
Maximum travel speed	Forward 38 km/h Reverse 38 km/h
Drive type	4 wheel drive
Tyre dimension	23.5 - 25 L5
Tyre pressure	Front 55 - 58 psi Rear 46 - 49 psi
Service brake type	Air over hydraulic dry disc brake
Parking brake	Electric pneumatic caliper
Service fill capacities	
Fuel	300 L
Hydraulic oil	240 L
Axles (main and final drives)	2 x 30 L
Engine	20 L
Transmission	21.8 L
Brake system	4 L
Hydraulics	
Type	Gear pump
Boom lift time	5.7 sec
Total cycle time	10 sec



SDLG machines are built to be like the people that own them: hardworking, genuine and reliable. Cost effective, robust machines with fuel efficient engines that are easy to operate and easy to maintain.

Everything about SDLG is designed to give you the confidence that you can complete the job to a high standard and on schedule. And when you need parts or service, you can trust your SDLG dealer to deliver on our promise. When you buy SDLG, you're buying reliability: **Reliability in Action.**



Congratulations SDLG for winning
EFQM Global Excellence Award
One of the top three quality awards in the world

PART OF VOLVO GROUP SINCE 2007

SDLG is member of the Volvo Group and one of the largest manufacturers of construction machinery in China, with a wide network of dealerships and service workshops throughout the world.

babcock[™]

Babcock International Group [SDLG Authorised Dealer]

19 Taljaard Road, Bartlett, Boksburg, South Africa
Tel +27 (0) 11 230 7300 | enquiries babcock.co.za | www.babcock.co.za

