

Reliability in Action

Wheeled Loader LG938L



Wheeled Loader L938L

LG 938L Features

- Different size standard buckets
- Side tip bucket
- Multi-function bucket (4-in-1)
- Pallet forks
- Log grapples
- Snow blade
- Attachment bracket and associated attachments

Specifications

Gross Vehicle Mass	10,700 kg
Rated bucket capacity (GP)	1,8m³
Rated load	3,000kg
Tractive force, maximum	≥ 105 kN
Breakout force, maximum	≥ 96 kN
Gradeability, maximum	30°
Dumping height, maximum	2,950 mm
Dumping reach, maximum	1,050 mm
General dimensions (LxWxH)	7,450 x 2,310 x 3,234 mm

Front (F) & Rear (R) Axles

Manufacturer	SDLG ZL30F (F&R)	Final Decelerate Type	Planetary gear reduction
Differential Reduction	Helical gear, first stage reduction		

Tyres

Type Specification	17.5 x 25/L3	Rear Tyre Pressure	2.75 - 2.9 Bar
Front Tyre Pressure	3.3 - 3.5 Bar		

Engine

Model	Weichai Deutz WP6G125E22	Rated Speed	2,200 rpm
Type	In line, direct injection, turbo charged, water cooled	Min.Fuel Consumption Ratio	≥ 207 g/kWh
Maximum Torque	560 Nm	No. of cylinders bore/stroke	6 - ø 105/120 mm
Rated Power	97 Kw		

Steering System

Type	Articulated load-sensing hydraulic steering
Steering Angle	38° each side

Transmission System

Make/Model	YD13	Gear Shifts	4 Forward 3 Reverse
Torque Converter Type	Single phase 3 element. Hydraulic	Maximum Speed	36 km/h
Torque Converter Ratio	3.0		
Transmission Type	Fixed shaft electro-hydraulic shift		

Minimum Turning Radius

Outside Bucket	6,020 mm	Outside Rear Wheel	5,470 mm
-----------------------	----------	---------------------------	----------

Hydraulic System

System Working Pressure	160 Bar	Total Time	≥ 8.6 s
Bucket Rise Time	≥ 5.3 s		

Brake System

Service Brake	Air over hydraulic disk brakes on 4 wheels
Parking Brake	Electrical internal expanding shoe

Fill Capacity

Fuel	140L	Hydraulic Oil	128L
-------------	------	----------------------	------

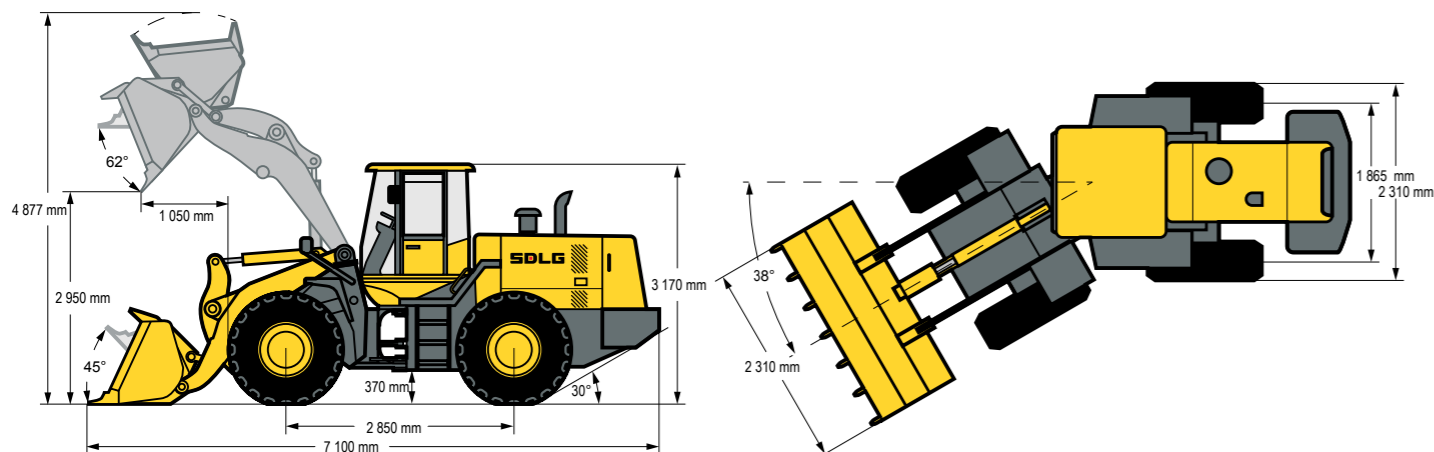

Fully enclosed ROPS/FOPS standard

Not all products are available in all markets. Under our policy of continuous improvement, we reserve the right to change specifications and design without prior notice. The illustrations do not necessarily show the standard version of the machine.



SDLG machines are built to be like the people that own them: hardworking, genuine and reliable. Cost effective, robust machines with fuel efficient engines that are easy to operate and easy to maintain.

Everything about SDLG is designed to give you the confidence that you can complete the job to a high standard and on schedule. And when you need parts or service, you can trust your SDLG dealer to deliver on our promise.

When you buy SDLG, you're buying reliability: **Reliability in Action.**



Congratulations SDLG for winning
EFQM Global Excellence Award
One of the top three quality awards in the world

PART OF VOLVO GROUP SINCE 2007

SDLG is member of the Volvo Group and one of the largest manufacturers of construction machinery in China, with a wide network of dealerships and service workshops throughout the world.

babcock™

Babcock International Group [SDLG Authorised Dealer]

19 Taljaard Road, Bartlett, Boksburg, South Africa
Tel +27 (0) 11 230 7300 | enquiries babcock.co.za | www.babcock.co.za

