



PORT MATERIAL HANDLER

WITH A REACH OF UP TO
29 m

875E Hybrid

The universal machine.

A smart approach to port logistics – the giant material handler with an operating weight of up to 170 t is right at home in the ports of this world. Numerous configuration options and customer-specific undercarriage solutions make it the ideal machine for industrial applications and demanding material handling tasks in ports.

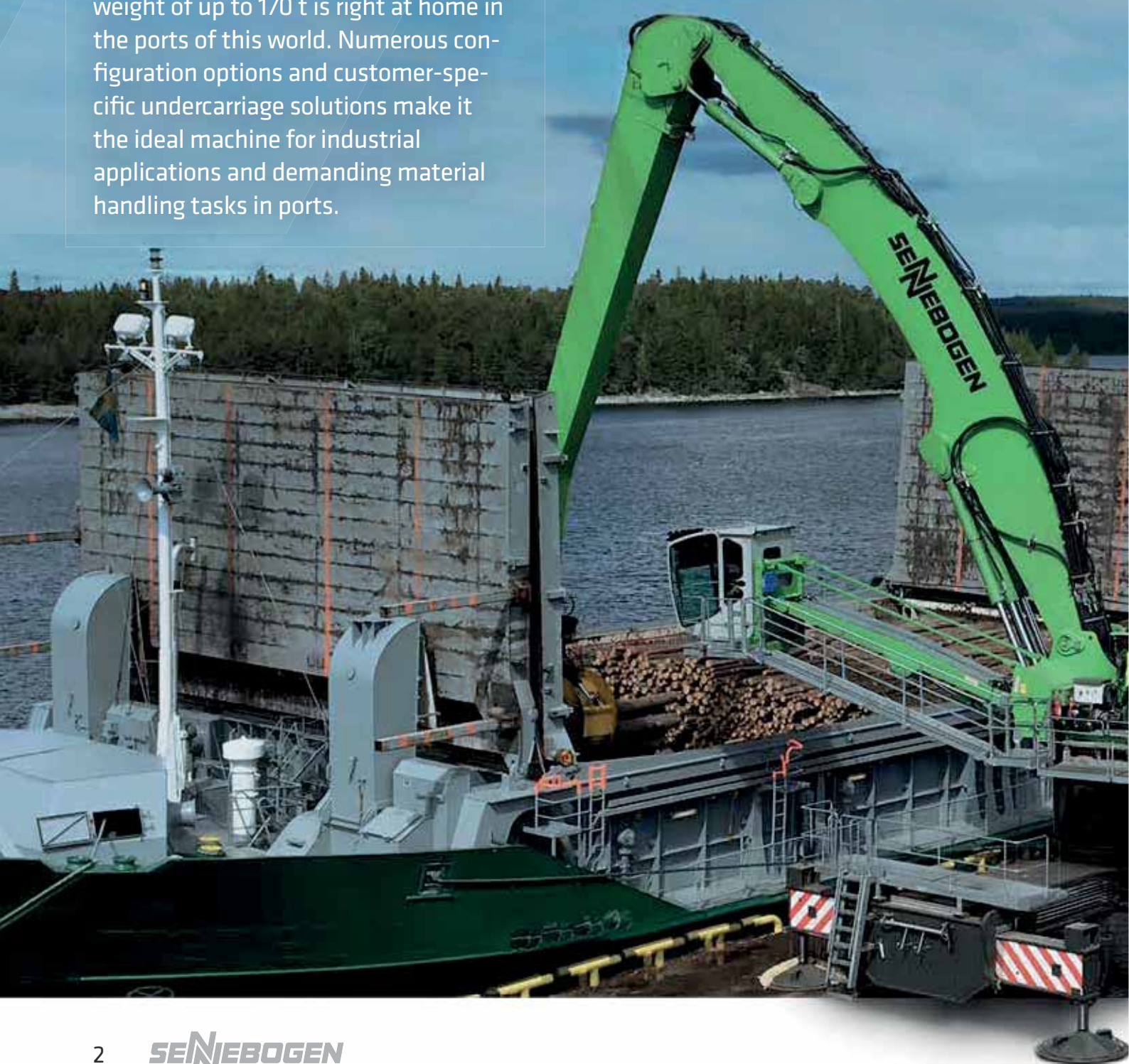

A long-term investment

The E-series is characterised by robust components, and an intelligent and resource-efficient machine design – the machine retains its value over the long-term, even with demanding continuous use.

Energy efficiency

Appreciated around the world, thanks to drives that are resource- and environmentally-friendly and the Green Hybrid energy recovery system – whether with diesel drive or as an electric version.

Occupational safety

Thanks to the precisely controlled movements and the numerous safety features, you can work effortlessly and safely throughout your day.

Modular variety

Unique machine variety – we build the perfect machine to meet the needs of your port.

Maximum comfort

The spacious cabs are designed with the needs of the operator in mind – comfortable and spacious with sophisticated features.

Maintenance & Service

Intelligent fleet management and machine status monitoring via the SENtrack portal as well as unique accessibility of machine components.



AN INVESTMENT THAT PAYS OFF.

The durability and reliability of the SENNEBOGEN Green Line is based on decades of experience in the design of high-quality crane and material handling technology. We can find the perfect solution for every port application, ensuring you can handle general cargo and bulk materials in an efficient and resource-saving way.



Low operating costs thanks to energy-efficient electric drives and energy recovery through the Green Hybrid system



Manageable and service-friendly technology for maximum machine availability



Consistent performance thanks to robust steel construction, and high-quality drive and control components from renowned manufacturers



High handling capacity of up to 1,200 t per hour* reduces the berthing time of ships



Sophisticated technology thanks to the consistent further development up to the 5th generation of the E-series – for demanding material handling



Durable and robust in extreme weather and harsh operating conditions, works equally well in the cold of the Arctic Circle or the heat of Dubai



>25,000
operating hours
for this 875 E in Turkey

Advanced. The E series.

LONG SERVICE LIFE, HIGH VALUE RETENTION

- Reliable and powerful thanks to its robust construction and high-quality components.
- Temperature-controlled cooling system, designed and tested for heavy-duty applications and high ambient temperature

SOPHISTICATED, STATE-OF-THE-ART TECHNOLOGY

- In the 5th generation – decades of experience in designing and constructing material handlers



EASY TO MAINTAIN AND SERVICE

- Technology that can be mastered and no over-engineering, optimum accessibility to all components

ENVIRONMENTALLY-FRIENDLY DRIVE TECHNOLOGY

- State-of-the-art engine, drive and emission systems in line with the latest technology standards (stage V)
- Large-scale pipes and valves for maximum efficiency

50 %

Save operating costs
by significantly reducing
energy consumption





SENNEBOGEN – WORLD LEADER IN ELECTRIC MATERIAL HANDLERS.

Over the last **35 years**, we have implemented by far the most electrical applications

- /// A complete solution direct from the manufacturer - detailed route analyses and individual power supply project planning, tailored specifically to your application
- /// A variety of solutions for power supplies, voltage types and emergency operating units ex works
- /// No fuelling stops or need to store fuel - always ready for use
- /// Service intervals twice as long as for diesel engines and lower service costs: no need for fuel / oil filters and oil changes
- /// High value retention and significantly longer service life
- /// No exhaust gas - good for the environment, good for people
- /// Low-noise and vibration-free operation for greater working comfort
- /// Cleaner engine compartment even after long service life

**GREEN HYBRID –
THE MOST SOPHIS-
TICATED ENERGY
RECOVERY
TECHNOLOGY
ON THE MARKET**





Save up to
50%
energy

GREEN HYBRID ENERGY RECOVERY TECHNOLOGY



Energy recovery with a safe and intelligent design: Watch the video to find out how the SENNEBOGEN Green Hybrid System makes port material handling even more efficient.

<https://www.sennebogen.com/green-hybrid>



1 Boom lowers, gas compresses



2 Energy storage module consisting of nitrogen piston accumulators



3 The nearly constant force transmission throughout the cylinder cycle supports the next boom lift

SENNEBOGEN GreenHybrid

Protects the environment, saves energy, reduces your costs.

- System advantages: large system volume and constant force transmission over the entire cylinder cycle
- System stability through constant pressure and temperature control
- Functional safety through the use of standard hydraulic components in the protected rear area of the machine
- System can be optimally adjusted to the individual task, depending on the weight of the material being handled
- Simple inspection and system filling via SENCON control system from the operator's seat

SAFETY FIRST.

Enjoy a safe work environment thanks to numerous safety features developed especially for port use. Protecting people, port and machine.



HOW TO OPERATE THE SAFETY BOOM LIFT



This video will show you how the SENNEBOGEN Safety Boom Lift works.

➔ <https://www.sennebogen.com/safety-boom-lift>

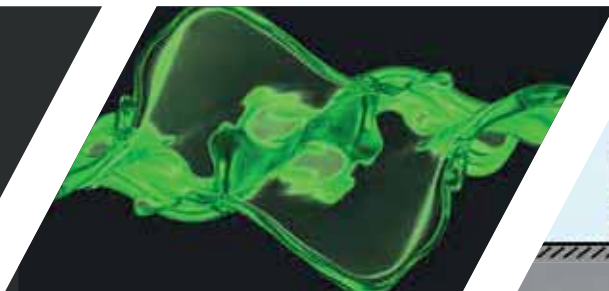

Bio Oil - Panolin

for extended oil change intervals, with safe environmental compatibility

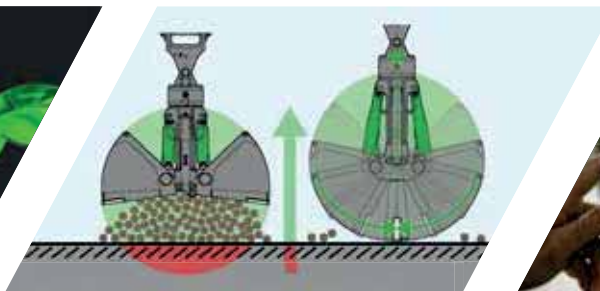

Safety Boom Lift

Grab automatically lifts as it closes, protecting ship hulls, port surfaces, equipment and the grab itself



SENtrack

Maintain fleet management safety by monitoring the condition of your machines



Component safety

maximum service life thanks to the robust steel construction - produced in our very own subsidiary

Safe & ergonomic

optimum cab and machine component accessibility via stairs and ascents



Powerful LED spotlights

for optimal illumination of the work area

Load moment limitation

Protection of equipment by switching off in the event of an impermissible load

Optimum camera monitoring

of all safety-relevant areas*

* Cameras are installed as standard on the righthand side and to monitor the rear area. Additional cameras, e.g. on the stick, are available on request.

EXPERIENCE VARIETY FOR EVERY TYPE OF MATERIAL

Today general cargo, tomorrow bulk cargo – working in the port means staying flexible from day to day. The entire range of material handling technology can be flexibly operated using the quick change system on the stick and the SENNEBOGEN port machines' powerful hydraulics.



Bulk material (feed, coal, etc.)



Scrap handling



Timber grab



Big Bag loading



Paper coil grab



Timber spreader/wooden pallet loading



Quick change system with lifting beam



Vacuum lifter



Pulp spreader

QUICK AND EASY GRAB CHANGE



Watch the video to see how quick and easy it is to change the grab with the quick change system on the stick!

<https://www.sennebogen.com/quick-coupler>

A MODULAR DESIGN. NUMEROUS APPLICATIONS.

EQUIPMENT

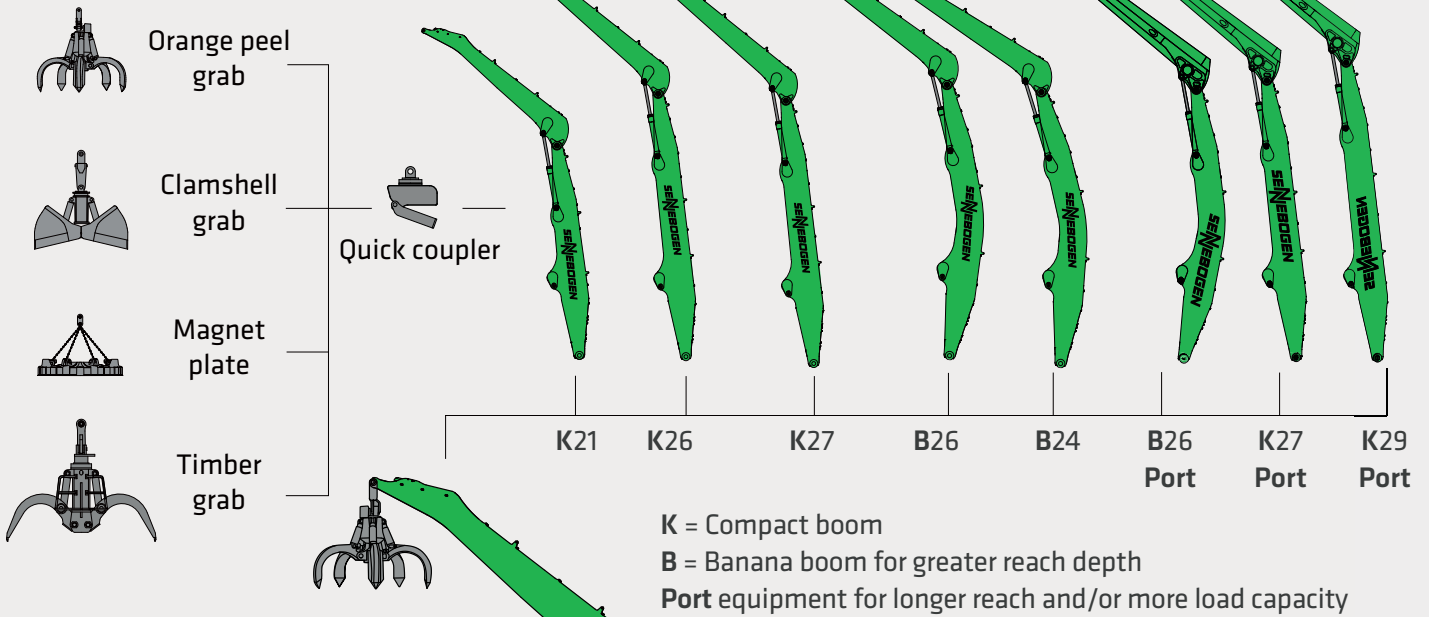

CAB

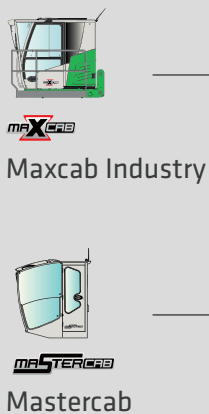

CAB ELEVATION

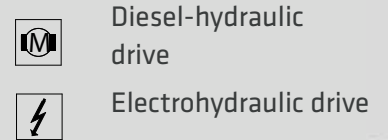

OPTIONS

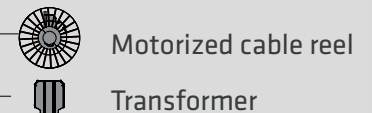

UPPERCARRIAGE

UNDERCARRIAGE

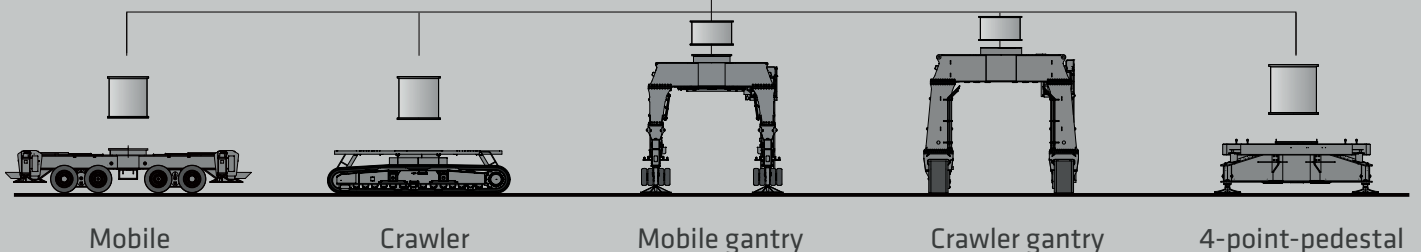

WHAT DOES YOUR MACHINE LOOK LIKE?

Configure your individual machine using our modular system. The great variety of solutions that we can implement in this way is unique.



CUSTOM CONFIGURATION

More than 16,000 unique material handling solutions can be delivered through SENNEBOGEN's modular machine design - watch the video now!

→ <https://www.sennebogen.com/versatility>

MAXIMUM COMFORT.



Everything in view

The spacious cab with panoramic view gives you a practical overview of your work area. The window in the floor makes it possible to carry out precise loading operations even in close proximity. The safety cameras provide support and allow you to monitor the critical areas conveniently via the monitoring system in the cab.

Easy control

The intelligent SENCON control system gives you quick and easy feedback on the machine's condition. Thanks to the intuitive user interface, it has never been easier to monitor energy consumption and utilization, control the desired working modes and contribute towards reducing operating costs.

For your health

Operators spend many hours in their working position. The back-friendly comfort seat, adjustable armrests, joysticks that sit comfortably in the hand, and the optimally arranged controls make daily work as easy as possible.

Pleasant indoor climate

Whether in warmer areas or in ports with sub-zero temperatures, you can enter a work space with a comfortable temperature every day and concentrate on the essentials of work thanks to automatic heating and air conditioning.

"We welcome regular feedback from operators to ensure the work space is configured perfectly."

ROBERT AUMÜLLER,
Head of the Port Business Unit



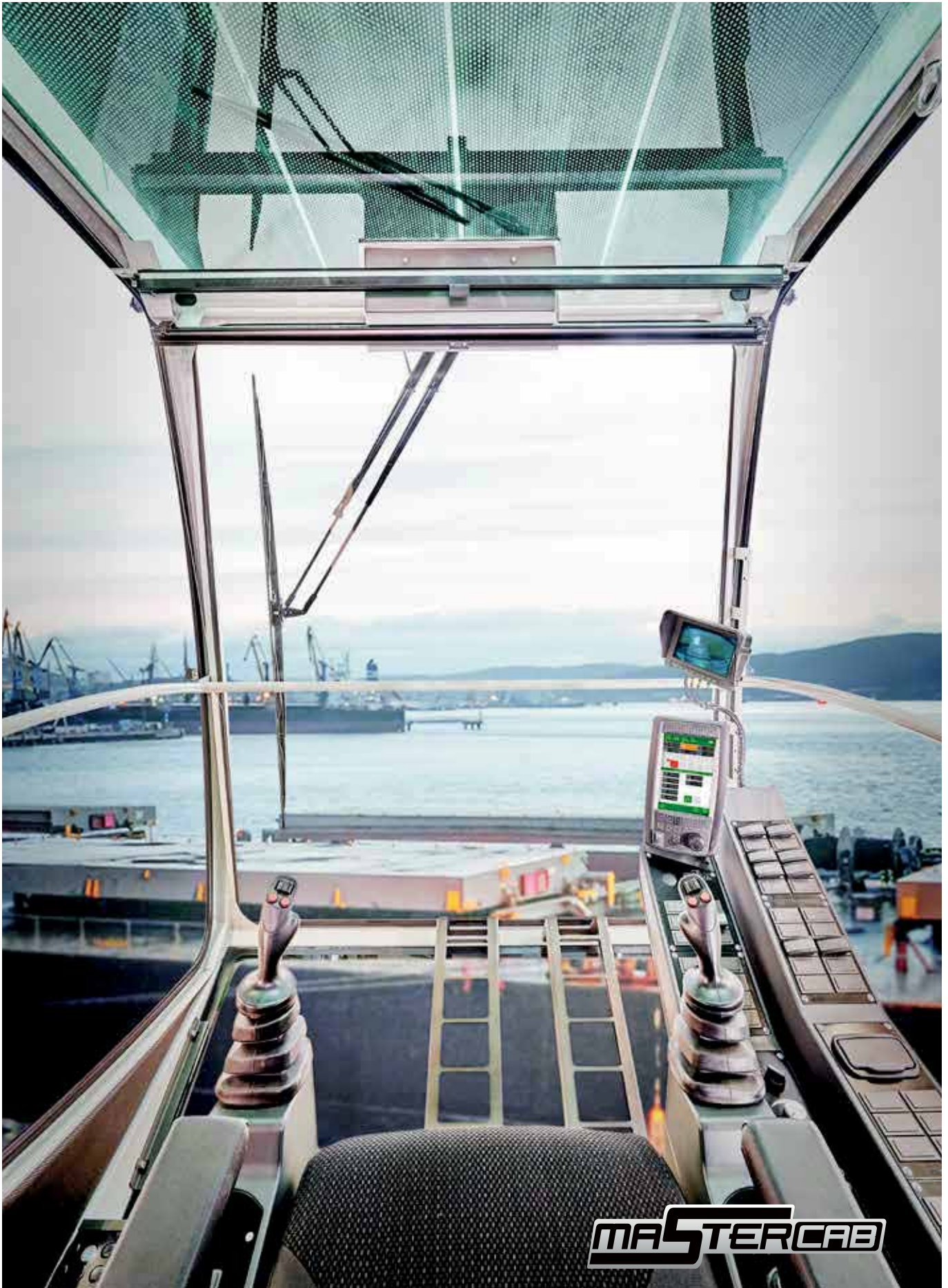

MASTERCAB

CAB HIGHLIGHTS



Maxcab premium cab in the industrial edition



The large capacity cab for the best all-round view of the port

IN SERIES



ENTRANCE

Sliding door incl. sliding window

Easy access through wide cab door

WINDSHIELD

Undivided windshield made from bullet proof glass, rigidly glazed

Tinted double glazing for side windows

SKYLIGHT

Skylight made from bullet proof glass

Large skylight with sun protection slats and windshield wiper with washing system

FLOOR WINDOW

-

Bullet proof glass floor window

WIPERS

Wipers for skylight

Parallelogram wipers for harsh weather conditions

Wiper

and washer system for front windshield

-

AIR CONDITIONER

Automatic heating/air conditioning with fresh air and recirculating air filter

Automatic air conditioning with optimised de-icing and demisting function

FLOODLIGHTS

Floodlights integrated into roof

Floodlights integrated into the uppercarriage and roof

FOLDAWAY SEAT

-

Foldaway seat in cab

RADIO



SENCON CONTROL AND DIAGNOSTIC SYSTEM



OPTIONS

AIR-CONDITIONED SEAT



RADIO



COOLING BOX BEHIND THE OPERATOR'S SEAT



PROTECTIVE GRILLE ON SKYLIGHT AND WINDSHIELD

-



SUN PROTECTION PACKAGE



ALWAYS THE RIGHT VIEWING ANGLE

The name 'Skylift' can be taken literally! Depending on the version and undercarriage being used, the flexible cab adjustment allows you to look into a ship's hull from around 13.5 metres. Thanks to a sophisticated system of steps, ascents and railings, access to the cab and maintenance points on the uppercarriage is safe and comfortable.

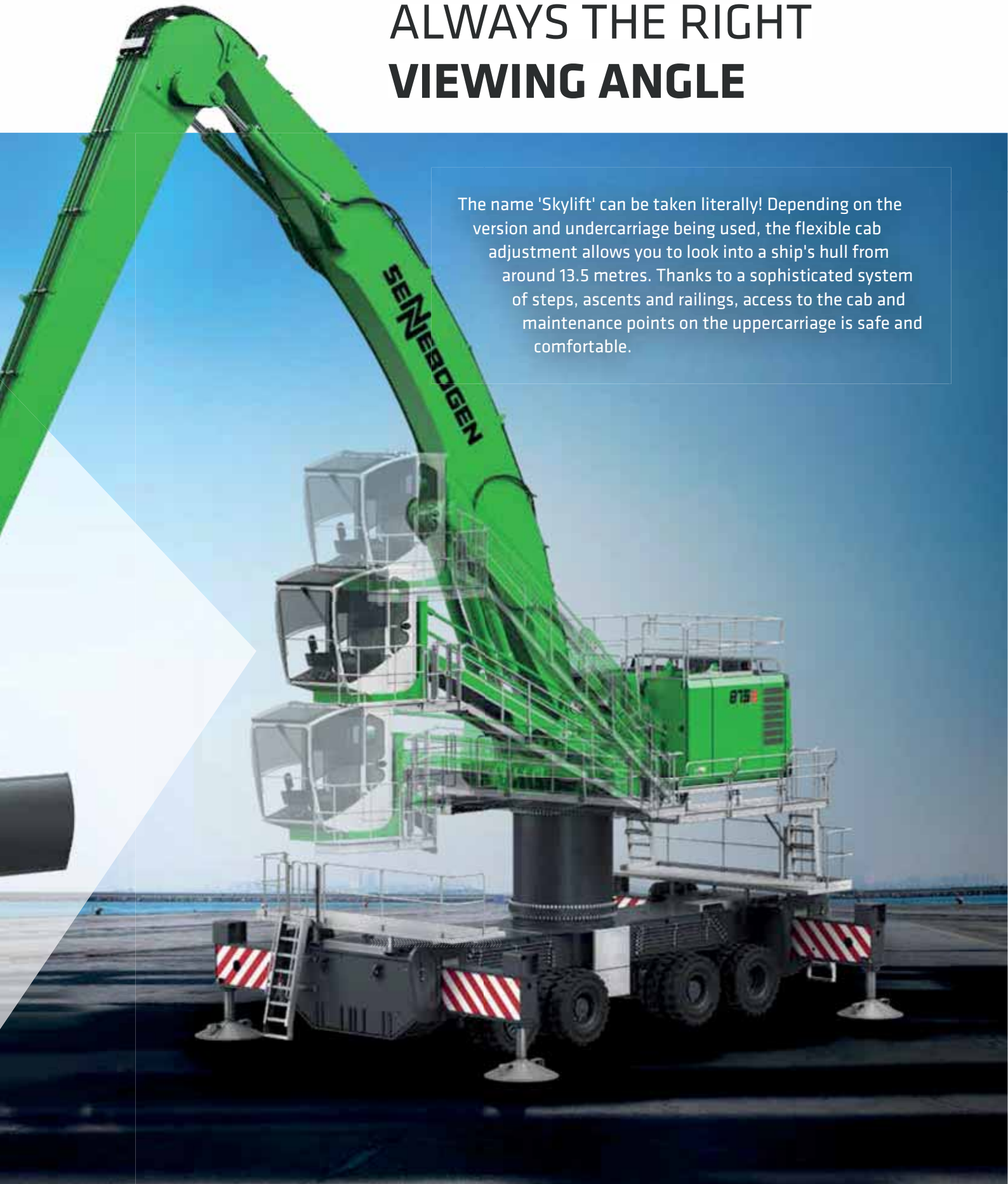

PROFESSIONAL FLEET MANAGEMENT

SENtrack

1. Reduce service costs

The dashboard is used to monitor the machine and its main operating parameters (temperatures, consumption). If key figures deviate significantly from the target value, preventive maintenance can be arranged.

2. Reduce consumption

You will receive daily updated insights into your fleet processes: Easily identify and optimize times when machines are idle or change set parameters when machines are underloaded to reduce consumption.

3. Improve productivity

With just a few clicks, you can identify and optimize machine capacity, analyse routes if required and thus make your port processes more profitable.

4. Safeguard your investment

Practical alarm messages inform you about critical machine conditions. In the event of irregular movements, the machine can also easily be deactivated remotely.

"What if you could receive real-time data from all your machines with just one click and so increase your productivity? SENNEBOGEN's SENtrack telematic system makes this possible."



MAINTENANCE AND SERVICE.

KEEP IT SIMPLE. WITH MANAGEABLE TECHNOLOGY.



Reliable and practical technology makes life easier. Where electronics add no value, we rely on hydraulics and electrical systems.



We make you happy, not reliant. With cost-effective components and fewer process steps, you can take care of your own machine.



The most important components, such as the accumulator module or the electrical distributor, are all easily accessible from a central point for straightforward checking and troubleshooting.



The SENCON control system supports you with diagnostics and makes troubleshooting easier. So your machine is back in action more quickly.



All maintenance and service points are clearly arranged and easily accessible. The clear labeling of components makes finding your way around easy.

TECHNICAL DATA, EQUIPMENT

MACHINE TYPE

MODEL (TYPE) 875 Hybrid

DIESEL ENGINE

TYPE Stage V:
Cummins X15 FR11813¹
Rated Power: 391 kW/1800 rpm
Operating point standard: 391 kW/1800 rpm
Operating point ECO: 374 kW/1650 rpm

Stage IIIa:
Caterpillar C15 Acert
Rated power: 433 kW/2100 rpm
Operating point standard: 433 kW/1800 rpm
Operating point ECO: 423 kW/1650 rpm

both: Automatic idle stop

COOLING water-cooled, charge air cooling, coolant cooling

DISPLACEMENT approx. 14 l (V) / approx. 15 l (IIIa)

NUMBER OF CYLINDERS 6

BATTERIES 2 x 210 Ah, battery disconnect switch

ELECTRICAL SYSTEM 24 V
Alternator: 105 A (V) / 95 A (IIIa)
Starter: 9 kW (V) / 8 kW (IIIa)

OPTIONS electrically heated fuel pre-filter water separator 24 V (IIIa)

Engine block heater

Engine oil preheating

Additional cyclone pre-separator for use in dusty environments

Electric fuel pump

TANK CAPACITY

FUEL 2100 l

ADBLUE 105 l

HYDRAULIC TANK 1400 l

COOLANT approx. 115 l

ENGINE OIL approx. 45 l (V) / approx. 68 l (IIIa)

CENTRAL LUBRICATION SYSTEM Automatic central lubrication for equipment and slewing ring, display of fault and empty message via SENCON

Lubrication pump with 16 kg reservoir (for min. 400 operating hours)

UPPERCARRIAGE

DESIGN Torsion-resistant box design, precision crafted, steel bushings for boom mountings. Service-friendly design, engine installed in the longitudinal direction

COOLING SYSTEM Cooling system with 3 cooling circuits and demand-driven fan control consisting of: Coolant cooling and hydraulic oil cooling, hydraulically driven, thermostatically controlled incl. fan reversal; charge air cooling driven directly by engine

OPTIONS LED lighting package
Swing bearing brake via foot pedal
Fire extinguisher
Maritime climate paint
Low temperature packages
Electrical hydraulic tank preheating
Magnet generator 25/33 kW

ELECTRIC DRIVE

OPTIONS **Type:** 390 kW, standard with frequency converter

Power: Total connected load 720 kVA, machine side fuse 800 A (also with generator) at 400 V - motor start via frequency converter

IP protection class: IP 55 standard, (IP 65 optional)



Optional: Power supply via motorized cable reel

TECHNICAL DATA, EQUIPMENT

HYDRAULIC SYSTEM

Load Sensing/LUDV hydraulic system, hydraulically controlled work functions

DELIVERY RATE 2x 475 l / min and 1x 274 l/min for slewing drive in the closed circuit

OPERATING PRESSURE up to 350 bar

CONTROL SYSTEM Proportional, precision hydraulic actuation of work movements, 2 hydraulic servo joysticks for the work functions, additional functions via switches and foot pedals

SAFETY Hydraulic circuits safeguarded with safety valves
Emergency lowering of the equipment in the case of engine standstill
Pipe fracture safety valves for lift and stick cylinders

OPTIONS Bio-oil filling
Tool Control for programming pressure/rate of up to 10 tools
Load torque warning with capacity display
Overload safeguard with shutdown
High-performance filtration with long-term change interval, SENNEBOGEN HydroClean micro-filter system with water separator

CAB²



CAB TYPE Maxcab Industry, can be elevated by 3 m and moved forward by 2.6 m

CAB FEATURES Maxcab Industry with sliding door incl. sliding window and undivided, flat windshield made from bullet proof glass, rigidly glazed, roof extended forward, bullet proof skylight, wipers and wash system for windshield, lower windshield wiper with washer nozzle, wiper for skylight, vibration damped, radio with antenna and loud speaker, 2 floodlights integrated into the front of the roof, SENCON control and diagnostic system

OPTIONS Spacious Mastercab
Skylift cab elevation (elevation 9 m)
Skylift cab elevation (elevation 7 m)
Windshield / skylight made of bullet proof glass (Mastercab)
Polycarbonate safety glass
Protective roof guard, FOPS if applicable
Protective front guard
Carbon filter for circulation/outside air
Auxiliary heating system
Air-conditioned seat
Radio
Cooling box

SLEWING DRIVE

GEARBOX Compact planetary gear with bent-axis hydraulic engine, integrated brake valves

PARKING BRAKE Spring-loaded multi-disk brake

SLEWING RING Strong, 3-row slewing ring, sealed. Externally geared slewing ring with 360° protection and pinion lubrication

SLEWING SPEED 0-5min⁻¹, stepless

SWING TORQUE 430 kNm

Optional: Working at a viewing height of up to 13.5 m thanks to Skylift cab adjustment



² Vibration level: Max. Hand/Arm (acc. ISO 5349-2001) < 2.5 m/s² and max. Body (acc. ISO/TR 25398: 2006) < 0.5 m/s²

TECHNICAL DATA, EQUIPMENT

UNDERCARRIAGE



MOBILE	Mobile undercarriage MS210 with integrated 4-point outriggers, all-wheel drive powered by a direct-mounted variable-displacement hydraulic engine, automatically operated brake valve and 2 stage power-shift transmission. Planetary axles with integrated steering cylinder, all-wheel drive
WIDTH	4450 mm
TIRE TYPE	Solid rubber 14.00-24 (16x); optional: 16.00-25
BRAKES	hydraulic
OUTRIGGER SIZE	Ø 1,300 mm
TRAVEL SPEED	0 – 6 km/h (mobile)

CRAWLER



Crawler undercarriage with hydraulic travel drive on each chassis side integrated in the chassis frame by an axial piston engine via compact planetary gears, spring-loaded parking brake, hydraulically ventilated multi-disk brake

UNDERCAR-RIAGEWIDTH	6,800 m
TRACK GAUGE	5,800 mm
PLATE WIDTH	1,000 mm
UNDERCAR-RIAGE LENGTH	8,500 mm

MOBILE GANTRY



WHEEL GAUGE	5,850 mm
TIRE TYPE	355/65-15 pneumatic tires; optional: 355/65-15 solid rubber
BRAKES	hydraulic
OUTRIGGER SIZE	Ø 1,600 mm
TRAVEL SPEED	2 – 4 km/h

CRAWLER GANTRY



UNDERCAR-RIAGEWIDTH	7,210 mm
TRACK GAUGE	5,850 mm
PLATE WIDTH	900 mm
UNDERCAR-RIAGE LENGTH	8,450 mm
RAIL GANTRY	Customized, tailored to your application, with hydraulic travel drive, 40 m/min travel speed
OPTION	Pylon extension



TECHNICAL DATA, EQUIPMENT

EQUIPMENT



REACH	up to 29 m
CYLINDERS	Hydraulic cylinders with high-quality sealing and guide elements, end position damping, sealed bearing points; all cylinders coated, nickel-plated and chromium-plated in a way that is suitable for maritime climates
OPTIONS	<ul style="list-style-type: none"> Safety Boom Lift for equipment Lift limitation / stick limitation adjustable to the stop settings LED lighting Stick mounted camera Special port equipment with increased load capacities

OPERATING DATA



REACH	up to 29 m
OPERATING WEIGHT	140 – 170 t, depending on model and equipment
NOTE	Operating weight varies by model and equipment.

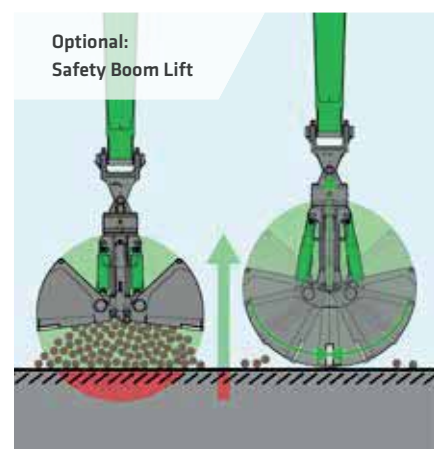
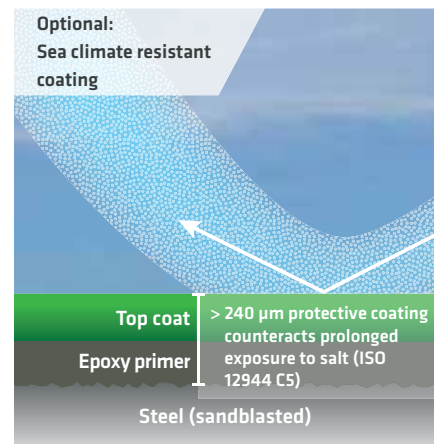

LOAD RATINGS K21 HEAVY LIFT

The load ratings are given as information only. Please contact our regional sales partners or portdivision@senebogen.de for a detailed project study.



R 147/580



MAXCAB INDUSTRY
can be elevated by 3 m and moved forward 2.60 m



12 m boom
10 m grab stick

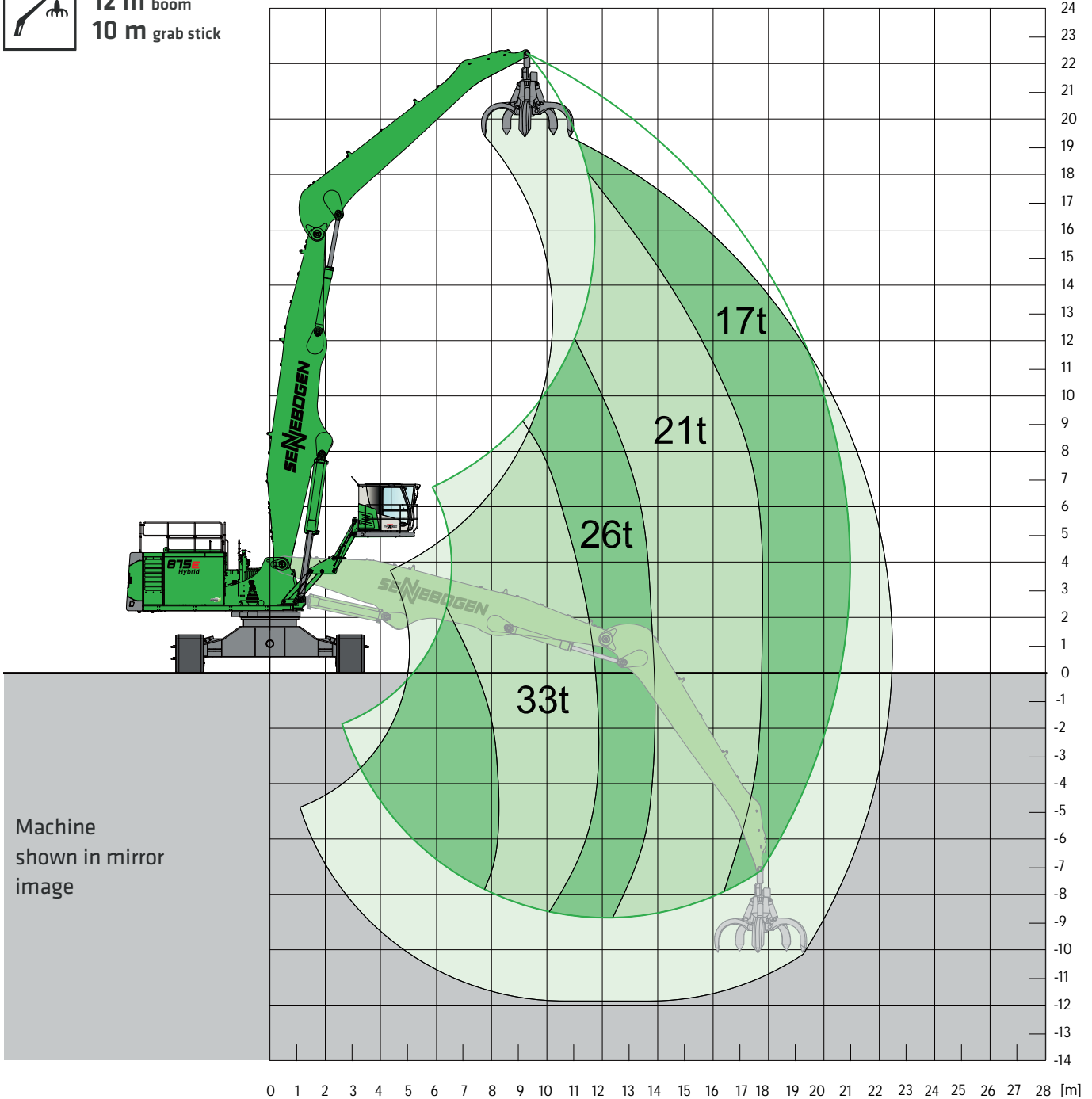

LOAD RATINGS

2020105140145

Notes:

All load ratings are given in tons (t) brought to bear at the end of the stick, without tools on firm level ground. Working tools such as grab, magnet, load-hook etc. are included in the specified load ratings. The stated values are 75 % of the static tipping load and 87 % of the hydraulic lifting force in accordance with ISO 10567 and apply after the required operating temperature has been reached in the Green Hybrid system. According to EU standard EN 474/5, material handling equipment used for hoisting must be equipped with a pipe rupture safety device on the lifting cylinder and an overload warning device. The specified load ratings apply to maximum track width and 360° slewing.

LOAD RATINGS K29 PORT

The load ratings are given as information only. Please contact our regional sales partners or portdivision@sennebogen.de for a detailed project study.



P 156/580



SKYLIFT 900 WITH MASTERCAB, hydraulically elevating (option)



16 m boom
14.5 m grab stick

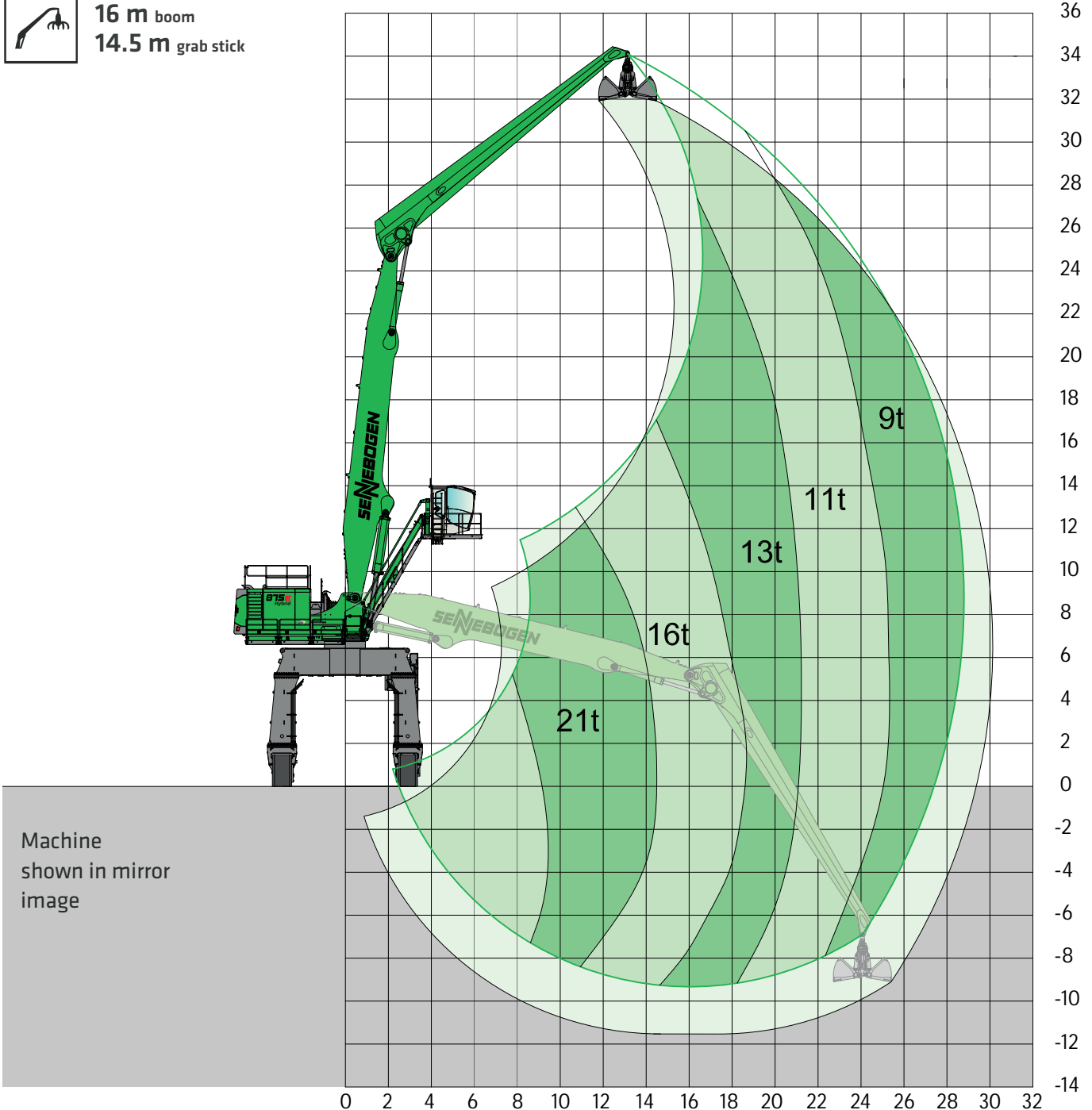

20180214174159

Notes:

All load ratings are given in tons (t) brought to bear at the end of the stick, without tools on firm level ground. Working tools such as grab, magnet, load-hook etc. are included in the specified load ratings. The stated values are 75 % of the static tipping load and 87 % of the hydraulic lifting force in accordance with ISO 10567 and apply after the required operating temperature has been reached in the Green Hybrid system. According to EU standard EN 474/5, material handling equipment used for hoisting must be equipped with a pipe rupture safety device on the lifting cylinder and an overload warning device. The specified load ratings apply to maximum track width and 360° slewing.

LOAD RATINGS B26 MOBILE GANTRY

The load ratings are given as information only. Please contact our regional sales partners or portdivision@sennebogen.de for a detailed project study.



PM150



SKYLIFT 900 WITH MASTERCAB, hydraulically elevating (option)



14.5 m boom
13.5 m grab stick

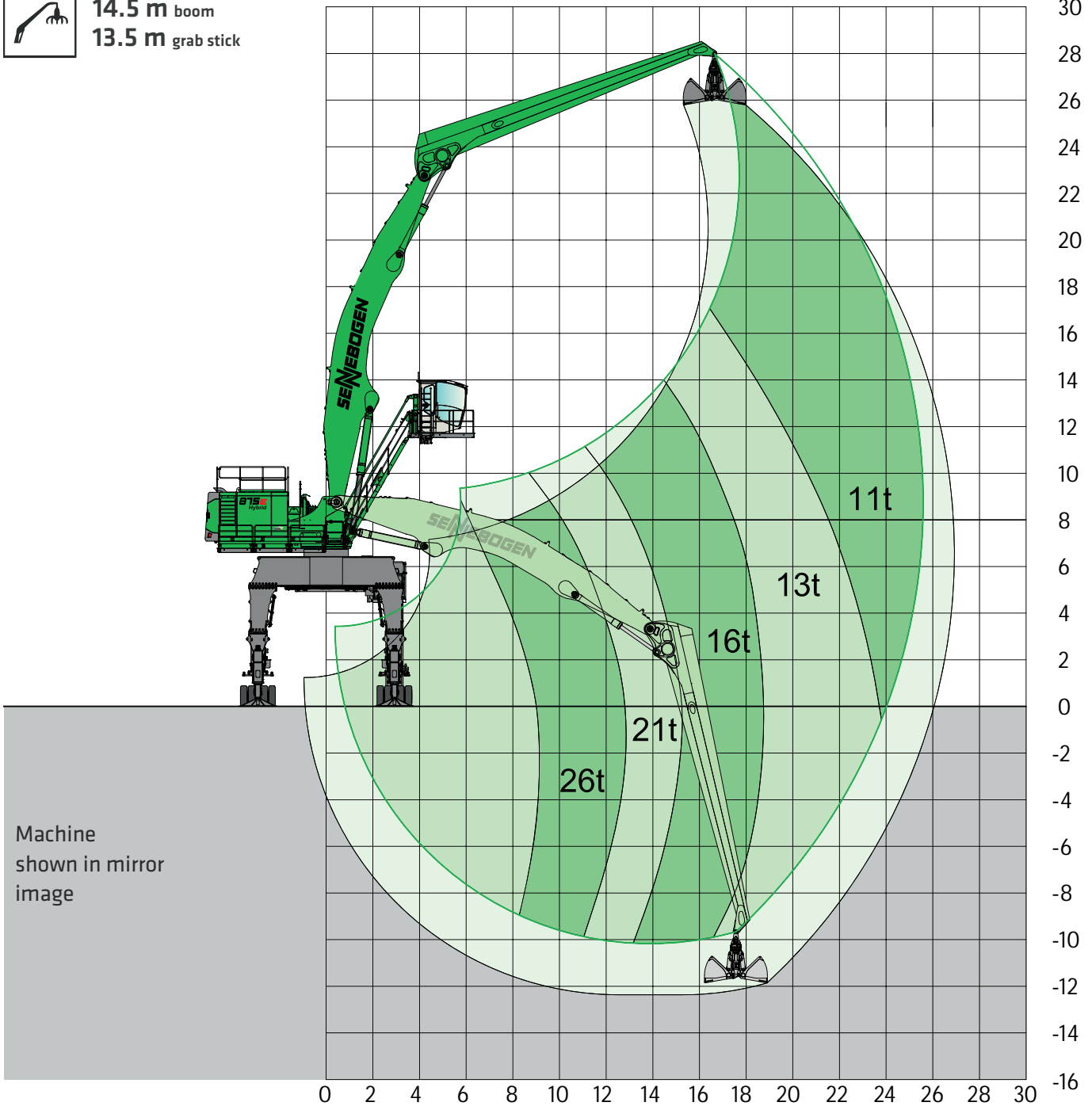

LOAD RATINGS

2018031611858

Notes:

All load ratings are given in tons (t) brought to bear at the end of the stick, without tools on firm level ground. Working tools such as grab, magnet, load-hook etc. are included in the specified load ratings. The stated values are 75 % of the static tipping load and 87 % of the hydraulic lifting force in accordance with ISO 10567 and apply after the required operating temperature has been reached in the Green Hybrid system. According to EU standard EN 474/5, material handling equipment used for hoisting must be equipped with a pipe rupture safety device on the lifting cylinder and an overload warning device. The specified load ratings apply to maximum track width and 360° slewing.



LOAD RATINGS

Mobile gantry for easy, flexible positioning on the quay

CRAWLER DIMENSION

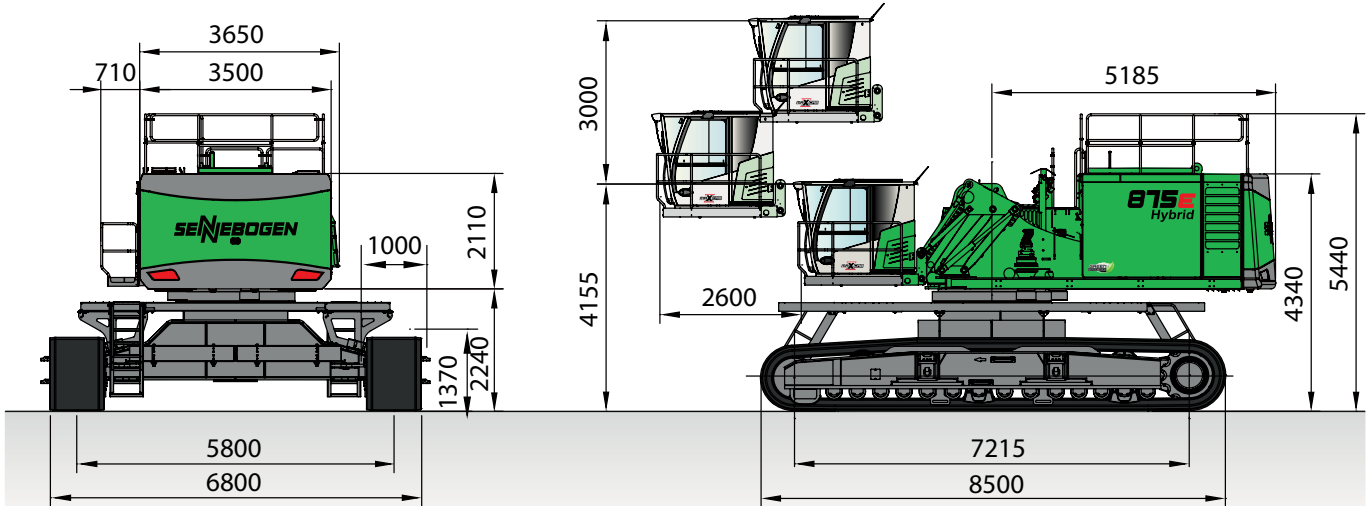

875 CRAWLER WITH R147/580 UNDERCARRIAGE AND E300/260 MAXCAB INDUSTRY (SERIES) WHICH CAN BE ELEVATED AND MOVED FORWARD HYDRAULICALLY

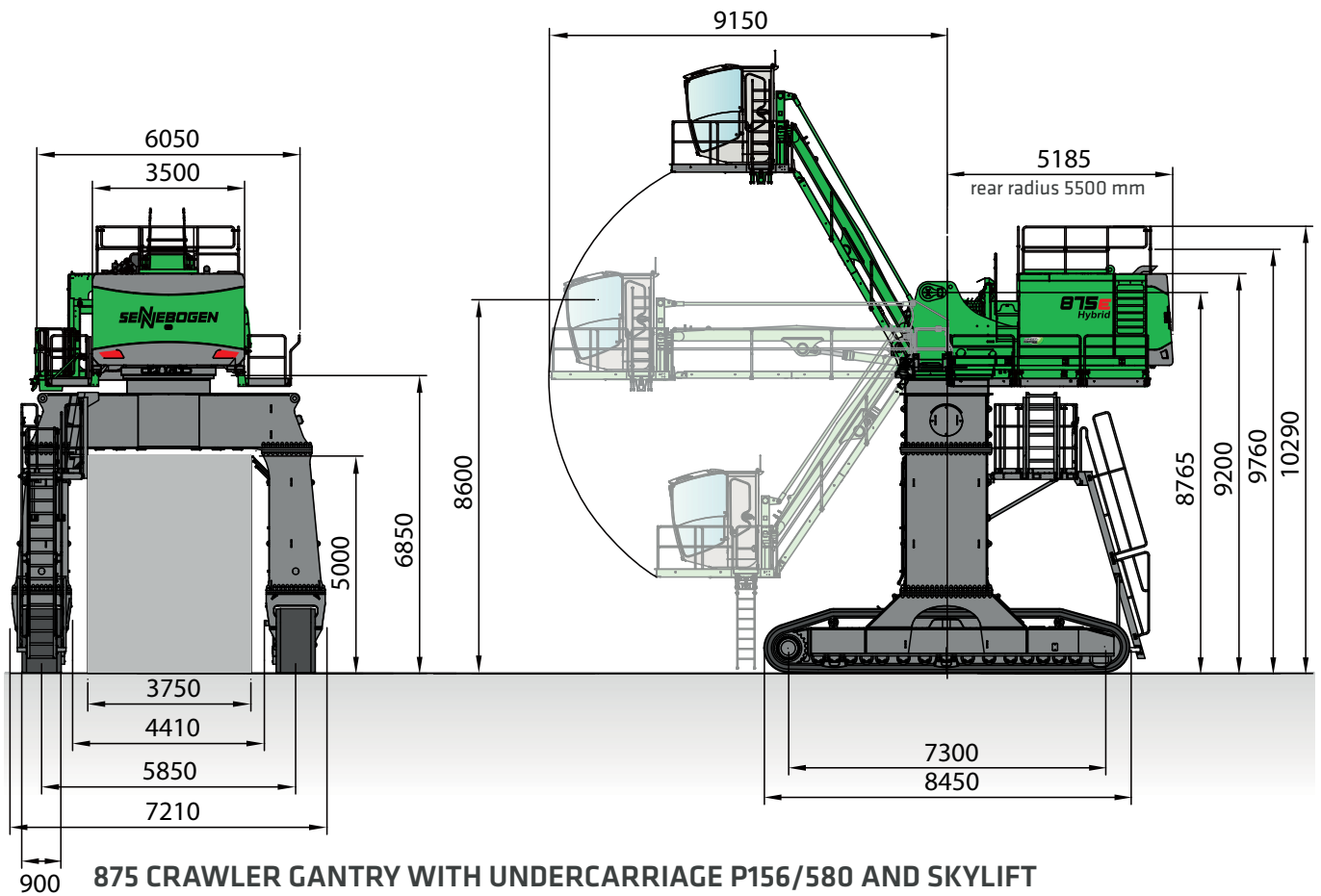

875 CRAWLER GANTRY WITH UNDERCARRIAGE P156/580 AND SKYLIFT 900 WITH MASTERCAB, HYDRAULICALLY ELEVATING

DIMENSIONS

MOBILE DIMENSIONS

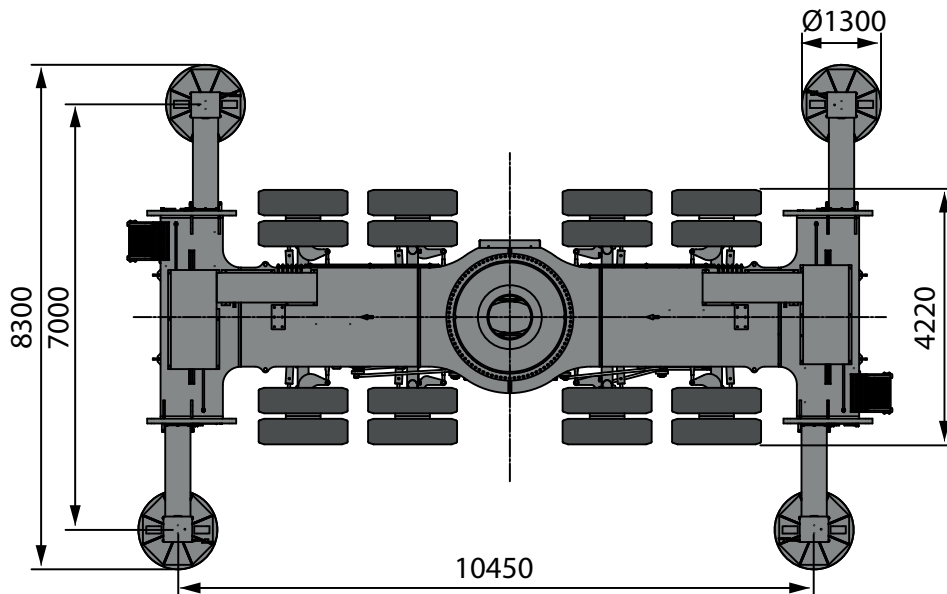
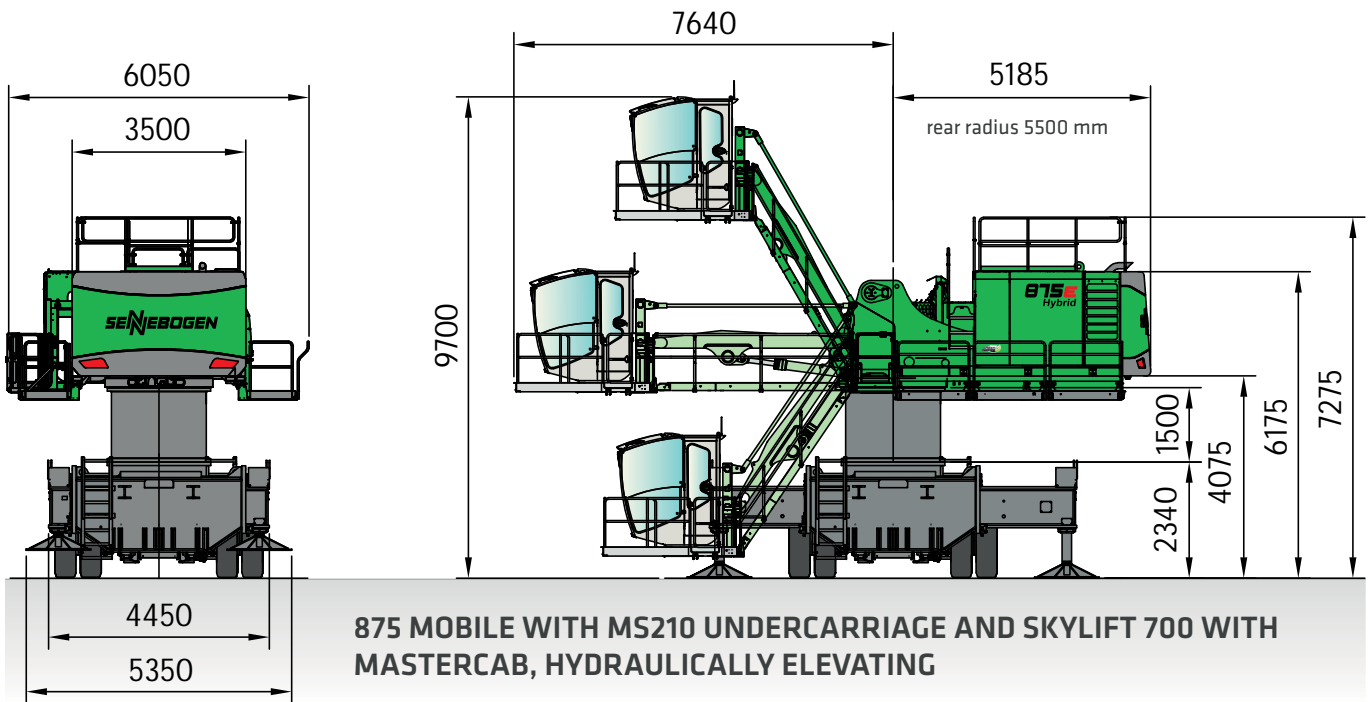

DIMENSIONS

MOBILE GANTRY DIMENSIONS

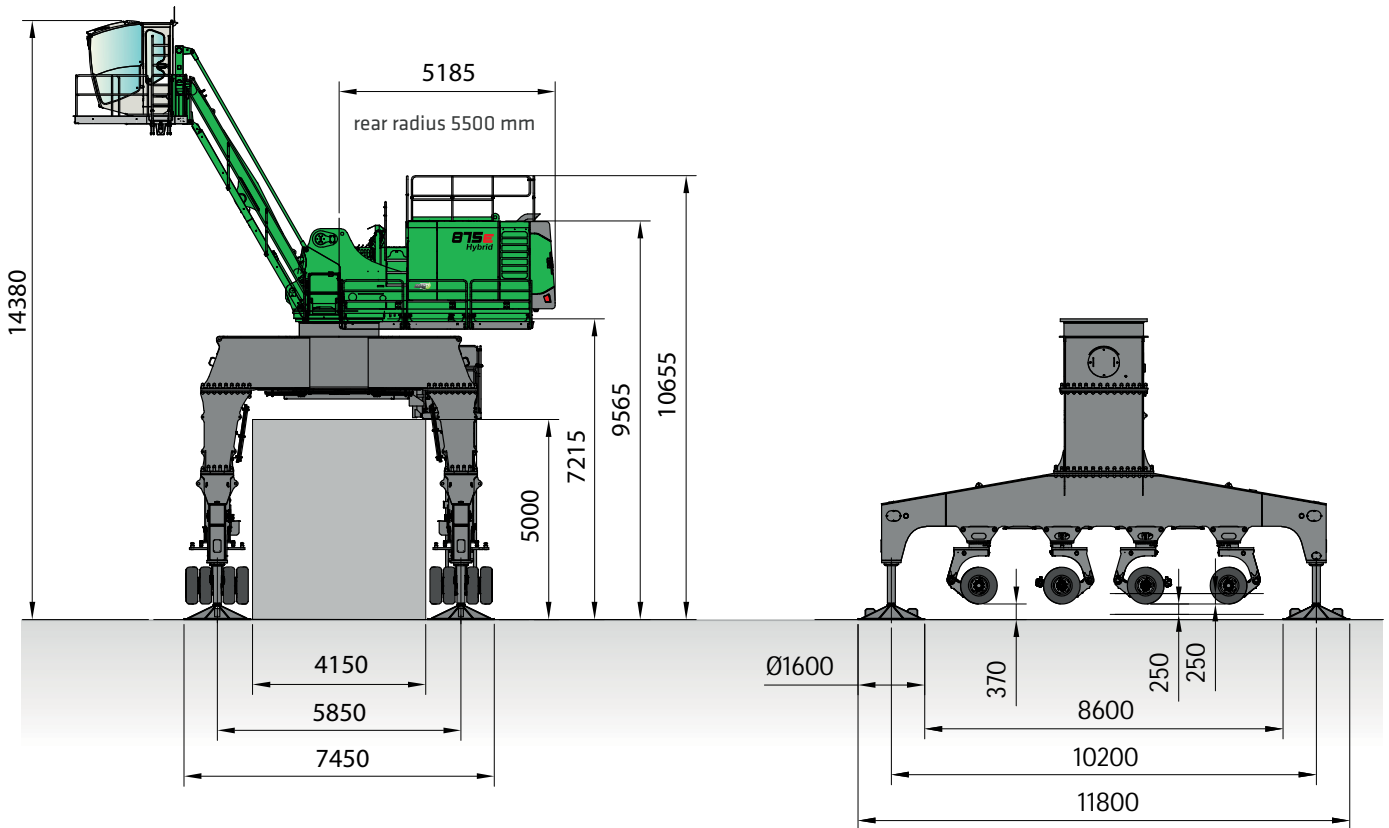

875 MOBILE GANTRY WITH PM150 UNDERCARRIAGE AND HYDRAULICALLY ELEVATING SKYLIFT 900 CAB ELEVATION AND MASTERCAB

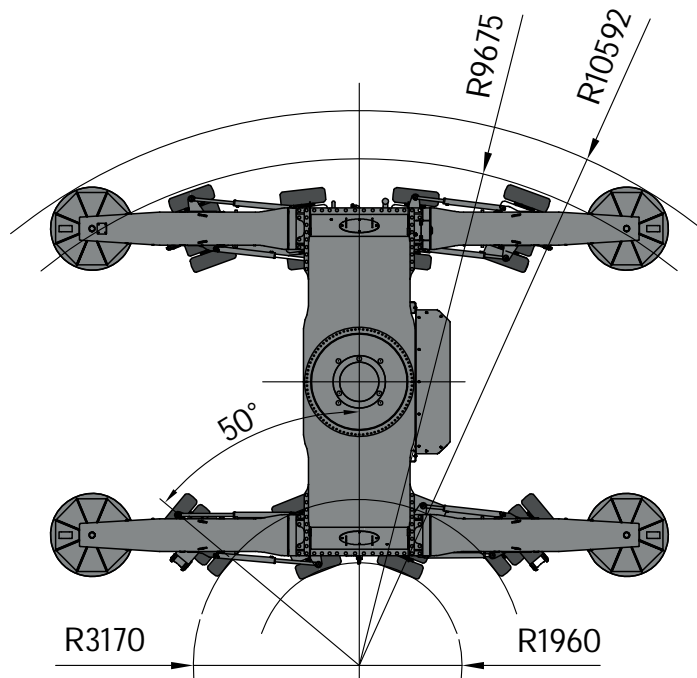

PM150 UNDERCARRIAGE



Customised rail gantry with electric drive, adapted to the specific rail track width in the port; Switzerland





SENNEBOGEN ACADEMY

Anxious to expand knowledge as success is based on knowledge. In the SENNEBOGEN Academy we place great importance on ensuring knowledge flows powerfully.

➔ www.sennebogen-academy.com



SERVICE AND MAINTENANCE

Comprehensive customer service. And supply of spare parts. Service is a TOP priority for us.

➔ www.sennebogen.com/customer-service



SENtrack

Manage your fleet efficiently with SENtrack: Use information that would otherwise stay hidden and increase your efficiency.

➔ www.sennebogen.com/sentrack



RENTAL & USED

Discover the unique range of rental machines available from SENNEBOGEN Rental & Used. Rental machines can be found here:

➔ www.sennebogen-rental-used.com

JOIN OUR OPERATORS' CLUB



The spotlight is on you and your machine! We focus on exclusive information, sharing experiences with other SENNEBOGEN operators as well as fun and enthusiasm.

Find out about all the benefits here

➔ www.sennebogen.com/operators-club



MOVE BIG THINGS - WITH US!



over **69**
years of experience

100 %
family
company

over **1600**
experienced special-
ists worldwide

4
production plants
in Germany

over **180**
sales and service partners
around the world

26
different
Material handlers



Telehandler
4.0-5.5 t

Balancer
130-300 t

Material handler
17-420 t

Duty cycle crane
13.5-300 t

Crawler crane
50-300 t

Telecrane
16-130 t

Port crane
300 t

875E | Hybrid

Order no. 299056
875-E-0721du

This catalog describes machine models, the scope of equipment of individual models, and configuration options (standard equipment and optional equipment) of the machines delivered by SENNEBOGEN Maschinenfabrik GmbH. Machine illustrations may contain optional and supplementary equipment. Actual equipment may vary depending on the country to which the machines are delivered, especially in regard to standard and optional equipment. All product designations used may be trademarks of SENNEBOGEN Maschinenfabrik GmbH or other supplying companies, and any use by third parties for their own purposes may violate the rights of the owners.

Please contact your local SENNEBOGEN sales partner for information concerning the equipment variants offered. Requested performance characteristics are only binding if they are expressly stipulated upon conclusion of the contract. Delivery options and technical features are subject to change. All information is supplied without liability. Equipment is subject to change, and rights of advancement are reserved. © SENNEBOGEN Maschinenfabrik GmbH, Straubing, Germany. Reproduction in whole or in part only with written consent of SENNEBOGEN Maschinenfabrik GmbH, Straubing, Germany.

SENNEBOGEN
Maschinenfabrik GmbH
Hebbelstraße 30
94315 Straubing, Germany

 www.sennebogen.com

MOVE BIG THINGS

SALES SENNEBOGEN
Green Line Sales
Tel. +49 9421 540-146
materialhandling@sennebogen.de

SPARE PARTS CENTER
Spare parts orders
spareparts@sennebogen.de

AFTER SALES
Technical support
service@sennebogen.de

